

ELEC 361 Measurement and Analysis

Lab 4. Optical Data Link

This lab investigates the performance of an infra-red optical data link to transmit synchronous and pulse width modulated (PWM) signals. You will build a simple infra-red data link using an infra-red LED (transmitter) and infra-red photodiode (receiver) as well as a simple PWM encoder, and decoder. You will test the link for quality, and by sending some music. This is a 2-week lab.

Pre-Lab Homework

1. Assigned reading:

- Read section 13.15 in *The Art of Electronics* - Horowitz and Hill (second edition). Read the parts on PWM.
- Look over the data sheets for the LM311 (comparator) and BC558 (switching transistor).

Background

Optoelectronic technology has become that data transport medium of choice since the introduction of high optical purity glass fibre cable and associated high-speed emitter and receiver devices. Applications range from infrared (IR) remote control units to 20 Gbit/s data links. Medium speed (< 1 Mbit/s) emitters use Light Emitting Diodes (LEDs) and higher speed emitters (>1 Gbit/s) use semiconductor LASER diodes. Medium speed receivers use standard photodiodes and higher speed receivers use avalanche types.

Optical data links may use packets of binary data to transfer digital messages. However some optical links send direct analog modulation e.g. 900 MHz GSM radio messages can be transmitted directly through fibre cable. The photoelectronic technologies are quite versatile and we will examine their application to a Pulse Width Modulation (PWM) data link.

A block model for the completed PWM encoder and optical link is:

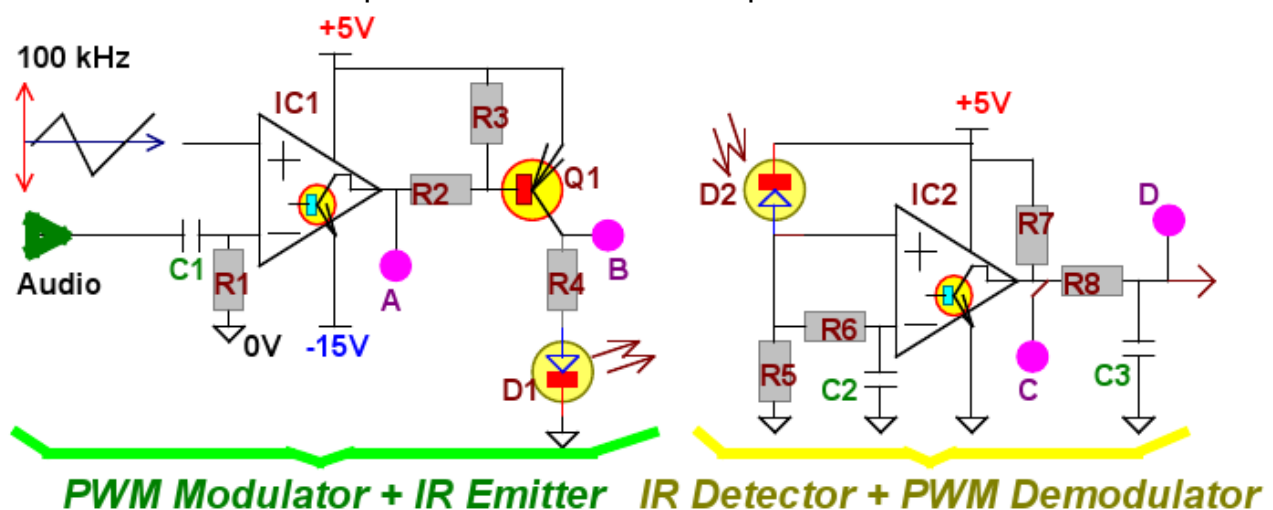

Lab tasks

PWM Modulator and Optical Link

The PWM modulator will operate at 100 kHz. ELVIS will generate a 100 kHz, 1 V peak triangle wave. This is applied to a comparator V+ input in conjunction with lower frequency audio signals applied to the comparator V- input.

The LM311 comparator has an open collector output that acts like a switch - it is ON when $V_+ < V_-$ and OFF when $V_+ > V_-$. The PNP transistor is used to drive the LED to increase the current drive capability to between 20 mA and 100 mA, depending on the value of R4.

Use the following component values:

| C1 | R1 | IC1 | R2 | R3 | R4 | Q1 | D1 |
|-------|---------------|-------|--------------|----------|-----|-------|--------|
| 100nF | 100k Ω | LM311 | 10k Ω | See text | 150 | BC559 | ZD1945 |

1. Consult the data sheets for pin-out data and assemble the PWM modulator
2. Apply a 100 kHz triangle wave from ELVIS AO_0 and monitor "A". Is it a square wave with 1:1 mark-space ratio?
3. Monitor "B" - is it inverted compared to "A"?
4. Choose a value for R3 that gives best 'rise' and 'fall' times.
5. Apply a 1 kHz sine wave to "Audio". Describe the waveforms at "A" and "B"

Optical receiver and PWM demodulator

Construct the PWM Demodulator on the ELVIS breadboard. Here is a suitable set of components:

| D2 | R5 | R6 | C2 | IC2 | R7 | R8 | C3 |
|---------------|--------------|---------------|----------|-------|---------------|--------------|-----|
| ZD1950/ZD1948 | 10k Ω | 100k Ω | See text | LM311 | 2.2k Ω | 10k Ω | 1nF |

6. Apply the triangle wave to the optical transmitter and position the LED and photo detector (ZD1948 photodiode) to have a direct optical path.
7. R6 and C2 provide a reference to comparator IC2 determined by the ambient light level. Determine a suitable value of C2.
8. Measure the voltage across R5 (0V to 1 V) using the scope
9. Measure the voltage at "C" Is it a square wave? Is it clean or noisy or distorted? If so, why?
10. Compare waveforms at "B" and "C" - are they similar? Is there a time delay from B to C? Can you measure rise time τ_r and fall time τ_f at B and C?
11. Apply a 1 kHz sine wave to "Audio". Measure the waveform at "D". Is the waveform sinusoidal?
12. Use the DSA. What is the distortion % at D
13. Repeat 6 with several Audio amplitudes. Repeat with 300 Hz and 3,000 Hz audio test frequencies
14. Connect the audio amplifier to D and apply the speaker to the terminal block on ELVIS. Can you describe the sound quality as the audio level is increased (use a 1 kHz tone)
15. Briefly compare your findings when the ZD1948 photodiode is replaced with a ZD1950 phototransistor.

Optical transmission of music by PWM

Now that the optical data link is functional, lets put it to a music test!

16. Load a mp3 music file into the PC and adjust the volume through its speakers
17. Plug the audio cable into the PC and connect it to Audio on the PWM modulator
18. Listen to the sound quality transmitted optically as PWM
19. Adjust the relative position of the LED and photodiode. Are there positions where the sound suddenly disappears and then comes back? Explain your findings.

Lab report

Present clearly all your results. Include all set-ups and measurements, and results derived from measurements. Describe how you made estimates from your measurements, and give the basis of calculations or code that you used. We want to see that you have understood how AM transmission of signals works, and how the circuits work.

Please note: Your lab book needs to me marked as 'completed' before you can hand in your lab report. You can only have one lab report outstanding (not graded as 'passed') to be able to start another lab.